



### Mixers

A Mixer is an analogue device that can multiply two signals together and also provides the difference of the two signals. They are composed of a non-linear device (a diode or a transistor) and passive couplers devices to inject the input mixing signals into the non-linear device that will perform the mixing. Current technology state-of-the-art in mixer realization shows that the bandwidth of mixers are limited by the passive devices and not by the diode or transistors, which have bandwidths exceeding the requirements.

Bandwidth of the mixer will be limited by the bandwidth of the couplers.

The multiplication process begins by inputting two signals:

$$a = A\sin(\omega_1 t + \phi_1) \text{ and signal } b = B\sin(\omega_2 t + \phi_2)$$

The resulting multiplied signal will be:

$$a.b = AB\sin(\omega_1.t + \phi_1).\sin(\omega_2.t + \phi_2)$$

This can be multiplied out thus:

$$\text{Using this trig identity } \dots \sin A \sin B = -\frac{1}{2} [\cos(A + B) - \cos(A - B)]$$

$$\text{Where } A = (\omega_1.t + \phi_1) \text{ and } B = (\omega_2.t + \phi_2)$$

$$= -\frac{AB}{2} [\cos((\omega_1.t + \phi_1) + (\omega_2.t + \phi_2)) - \cos((\omega_1.t + \phi_1) - (\omega_2.t + \phi_2))]$$

$$= -\frac{AB}{2} [\cos((\omega_1 + \omega_2)t + (\phi_1 + \phi_2)) - \cos((\omega_1 - \omega_2)t - (\phi_1 - \phi_2))]$$



Sum frequency  
(removed by filtering)



Difference frequency ie  
I.F

**Mixer Definitions**

**(1) Conversion Gain:** This is the ratio (in dB) between the IF signal (usually the difference frequency between the RF and LO signals) and the RF signal.

**(2) Noise Figure:** Noise figure is defined as the ratio of SNR at the IF port to the SNR of the RF port.

**(i) Single sideband (SSB):** This assumes the only noise from the signal  $\omega_1$  and not the image frequency  $\omega_1-1$ , this would be the case if a band-pass filter was added in front of the mixer eg.

RF = 1694 MHz, LO = 1557MHz to give an IF of 137MHz.

Also an image IF will add to 137MHz from an RF of 1420MHz ie 1557MHz-1420MHz = 137MHz as shown in

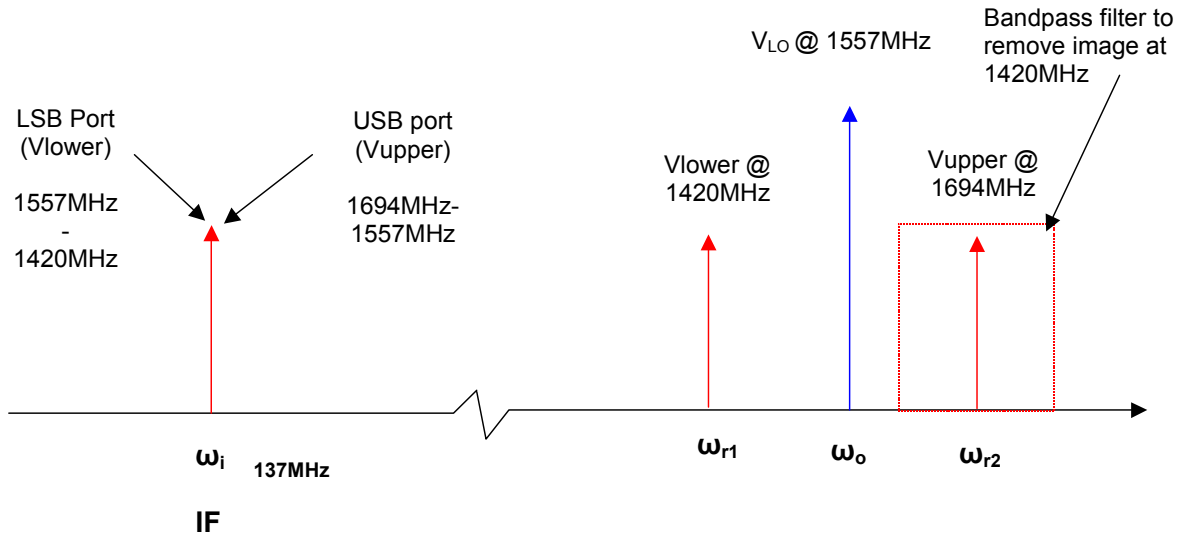
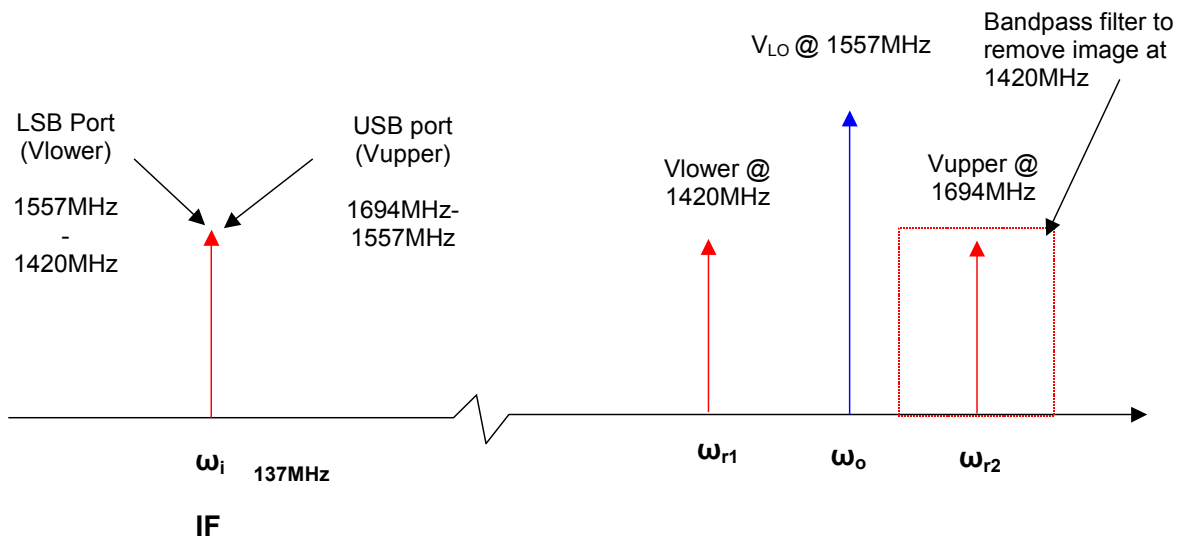

Figure 1.





**Figure 1 Single-sideband conversion of image noise to IF of 137MHz. The image response at 1420MHz will also produce a signal at the IF and (in the absence of a carrier) will down convert noise. This is overcome by adding a band-pass filter at 1694MHz.**

In this situation the addition of a band pass filter at 1694MHz will eliminate the image response.



**(ii) Double sideband (DSB):** In DSB both sidebands are available thus it has twice as much power available at the IF port compared to the SSB signal. As a result, its conversion loss is 3dB less than that of an SSB signal, as shown:

$P_{(IF)DSB} = 2 P_{(IF)SSB}$  and conversion loss is given by

$$(LC)_{DSB} = (LC)_{SSB} - 3(dB) \text{ or in terms of loss ratios } (LC)_{DSB} = \frac{(LC)_{SSB}}{2}$$

### DSB to SSB Noise Figure

$F_m = 1 + (LC - 1) \frac{T}{T_o}$  Where T = temperature of mixer,  $T_o$  = room temperature (273°K)

For DSB,  $(LC)_{DSB} = \frac{(LC)_{SSB}}{2}$  Therefore,  $F_{m(DSB)} = 1 + \left( \frac{(LC)_{SSB}}{2} - 1 \right) \frac{T}{T_o}$

At room temperature, ie  $T = T_o$

$F_{m(DSB)} = \frac{(LC)_{SSB}}{2}$  in other words  $F_{m(DSB)}$  is half or 3dB less than  $F_{m(SSB)}$

$F_{m(DSB)} = F_{m(SSB)} - 3(dB)$

### Isolation

These parameters define how much signal leakage will occur between pairs of ports. ie RF to LO, LO to IF and RF to IF. So if for example RF to IF isolation was specified at 35dB this means that the RF at the IF port will be 35dB lower than the RF applied to RF port.

Most systems will specify some form of spurious specification on the output so RF and LO signals may cause problems leaking through the mixer to the IF port and may require additional filtering at IF to remove.

**Linearity**

**(i) 1dB Compression point**

Like other non-resistive networks, a mixer is amplitude-nonlinear above a certain input level resulting in a gain compression characteristic as shown in Figure 2.

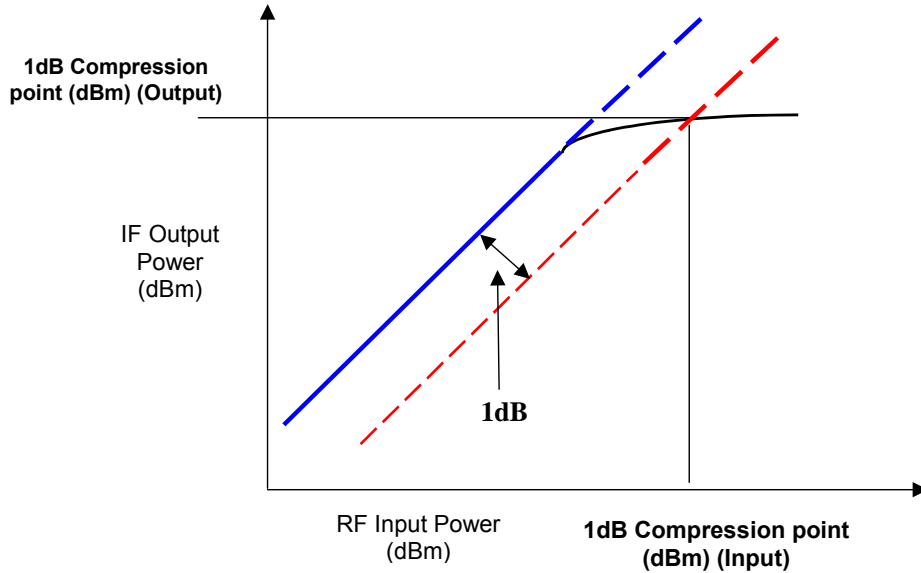

**Figure 2 Typical gain compression characteristic for a non-linear Amplifier/Mixer, showing the measurement of the 1dB compression point.**

Above this point the If fails to track the RF input power level – normally a 1dB rise in RF power will result in a 1dB rise in the IF power level. The 1dB compression point is measured by plotting incident RF power against IF power as shown in the figure above.

Most mixers have the 1dB compression point specified at the input ie the single-tone input signal level at which the output of the mixer has fallen 1dB below the expected output level.

For typical double balanced mixers this figure is ~ 6dB below the LO power level. (So performance can be improved by overdriving the LO port).

The 1dB compression point gives rise to the **dynamic range** of the mixer, which is the difference between the 1dB compression point and the minimum discernable signal (MDS – this is dependant on the noise floor of the device).

**(ii) Intermodulation (IM3) performance**

This parameter is the same as specified for amplifiers and measured in a similar way. It is measured by applying two closely spaced input tones at frequencies  $F_1$  and  $F_2$ . Third order products from the mixing of these tones with the LO (at frequency  $F_{LO}$ ) occur at frequencies given by:  $(2F_1 \pm F_2) \pm F_{LO}$  and  $(2F_2 \pm F_1) \pm F_{LO}$ . In the case of the mixer, the third order products of most interest are  $(2F_1 - F_2) - F_{LO}$  and  $(2F_2 - F_1) - F_{LO}$  as they fall in, or close to the IF band.

The IM3 performance is often summarised by giving the 3<sup>rd</sup> Order Intercept point (IM3 Intercept) as shown in the compression characteristic of Figure 3, where the IM3, IM5 plots intersect with the extrapolated gain plot (blue dotted line). As a rule of thumb the IM3 intercept point is approximately 10dB above the 1dB compression point.

This figure of merit gives an indication of the mixer's signal handling capability. In particular it provides an indication of the levels of third order products a mixer is likely to produce under multi-tone excitation.

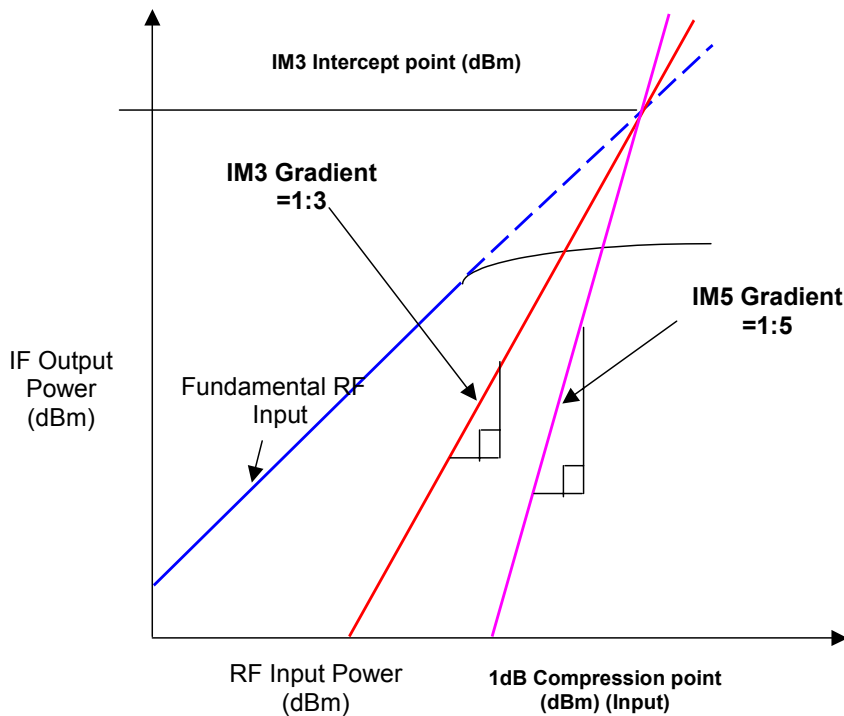

**Figure 3 IM3 gain compression characteristic, as a rule of thumb the IM3 intercept point is approximately 10dB above the 1dB compression point.**

The IM3 and IM5 graphs will intersect the fundamental graph at the intercept point. (Note the IM2 intercept point will be different and usually a lot higher).



Again, for mixers the measurement is referred to the input ( $IP_{3,in}$ ) and is given by:-

$$IP_{n,in} = \frac{IMR}{(n-1)} + \text{Input power(dBm)}$$

Where IMR = Intermodulation ratio (The difference in dB between the desired output and spurious signal) and n = the IM order.

Typically, for double balanced mixers  $IM_{3,in}$  is ~ 14dB greater than the single tone 1dB compression point and ~ 8dB greater than the LO power.

### Mixer Types

Mixers can be first divided into active or passive. Passive mixers primarily use Schottky diodes, or are FET resistive mixers, that use the resistive channel of a MESFET to provide low-distortion mixing with the same conversion loss as a diode mixer. Active mixers use FET or bipolar devices.

Although single-device mixers are used occasionally, most practical mixers are balanced, and require baluns or hybrids, that determine the bandwidth and overall performance of the mixer.

Diode mixers have an important advantage over FETs and bipolar devices: a Schottky-barrier diode is inherently a resistive device, and as such has very wide bandwidth. The bandwidths of diode mixers are limited primarily by the bandwidths of the baluns, not the diodes. FETs, in contrast, have a high-Q gate-input impedance, causing difficulties in achieving flat, wide bandwidth.

Diode mixers usually have 5-8 dB conversion loss, while active mixers usually can achieve at least a few dB of gain. Although properly designed active mixers can achieve somewhat lower noise figures than diode mixers, most systems can tolerate a relatively noisy mixer, so the diode mixer's loss and noise are rarely a significant disadvantage. Broadband diode mixers usually do not require more local-oscillator (LO) power than active mixers, but narrowband active mixers may have an LO-power advantage. Finally, balanced active mixers always require an IF hybrid or balun; diode mixers generally do not. When the IF frequency is low, the resulting large size of the IF balun may be troublesome, especially in monolithic circuits. Finally, even balanced active mixers require matching and filtering circuits, while balanced diode mixers largely do not.

Active mixers have a few important advantages over diode mixers besides their superior gain and noise figure. High-quality diodes are often difficult to produce in FET monolithic circuit technologies, so active FET mixers often are easier to integrate. Diodes in such technologies usually consist of a FET gate-to-channel junction, which usually is a very poor diode. Dual-gate FET mixers offer inherent LO-RF isolation, even in single-device circuits, although noise figure and gain usually are slightly worse than in single-gate FET mixers.



### **Singly Balanced Diode Mixers:**

Advantages:

- Provide either LO or RF Rejection (20-30 dB) at the IF output
- Rejection of certain mixer spurious products depending on the exact configuration
- Suppression of Amplitude Modulated (AM) LO noise

Disadvantages:

- Require a higher LO drive level

### **Doubly Balanced Diode Mixers:**

Advantages:

- Both LO and RF are balanced, providing both LO and RF Rejection at the IF output
- All ports of the mixer are inherently isolated from each other
- Increased linearity compared to singly balanced
- Improved suppression of spurious products (all even order products of the LO and/or the RF are suppressed)
- Reasonable conversion loss on signal RF (about 7dB)
- Consumes no power except for the losses incurred in conversion
- Broadband in nature and therefore suited to multi-band designs
- High intercept points

Disadvantages:

- Require a higher LO drive level
- Require two baluns
- Relative high noise figure, about the same as the conversion loss
- Ports highly sensitive to reactive terminations.
- High quality, high speed diodes which will take the necessary saturating current and large reverse voltages across the non-conducting diodes are an absolute must where performance counts
- Diodes need to be well "matched"
- The transmission line transformers require great care in design and construction. The actual construction will determine the bandwidth.

### **Double Doubly Balanced Diode Mixers:**

Advantages:

- Increased linearity

Disadvantages:

- Increased complexity (3 baluns and 8 diodes are required)
- Higher level of LO drive must be provided

Note: for increased linearity an alternative approach is to use a FET resistive mixer. This can yield even higher linearity than the double doubly balanced topology whilst having a simpler circuit configuration.



**Active FET Mixers:**

Active FET Mixers are transconductance mixers using the LO signal to vary the transconductance of the transistor.

Advantages:

- Provide conversion gain
- Lower noise figure than passive mixers

**Single gate FET Mixers:**

Advantages:

- Low component count.
- Good for X-Band designs

Disadvantage:

- some form of diplexing is required to separate the LO and RF inputs which are incident on the same port.

**Dual gate FET Mixers:**

Advantages:

- No LO and RF diplexing is required,
- LO and RF signals are inherently isolated

Disadvantage:

- Shortage of suitable devices at higher frequencies.

**Image Reject Mixers:**

Image reject mixers comprise two balanced mixers, of any topology, driven in quadrature by the LO signal as shown in . The RF drive to each mixer is in-phase (split by a in-phase hybrid eg Wilkinson power Divider) and the IF output is combined in quadrature.

Advantages:

- Possible to achieve 20 dB of image frequency rejection

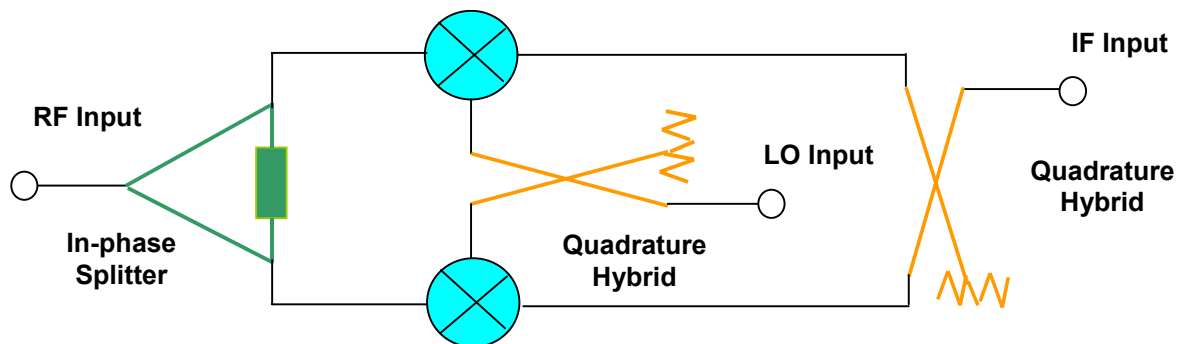

**Figure 4 Schematic diagram of an image reject mixer. Here the mixers are fed with the LO drive in quadrature, and the RF fed in phase (Split using a Wilkinson power splitter for example). The two IF's from the mixers are combined in quadrature.**



The table shown below in Table 1 gives a summary of key features/advantages for each active and passive mixer type.

	LO rejection	RF rejection	Rejection of spurious	Suppression of AM noise	LO power level	Linearity	Conversion loss on signal RF	Broadband	IP point	NF	Complexity	Diplexing	Image freq rejection
Single diode					Low	Poor	Low	√					
Singly balanced diode	√*	√*	certain	√	high								
Doubly balanced diode	√	√	even	√	High	Better	7dB	√	High	Rel high	4diode 2balun		
Double doubly balanced diode	√	√	even	√	Very high	Increased					8diode 3balun		
Active FET							Gain			Lower than passive			
Single gate FET												required	
Dual gate FET												Not req.	
Image reject											2 mixers, 3 hybrids		20dB

\* LO or RF rejection to choose

**Table 1 Comparison Table of mixer types and their characteristics**